

Available on request:
220-240 V/~60 Hz
110-120

SPEED 50-G CH #305008
housing, grille and tubular
frame chrome finish, blade
matt black

modern technical
design
can be used wall
mounted and with
chain suspension
strong airstream

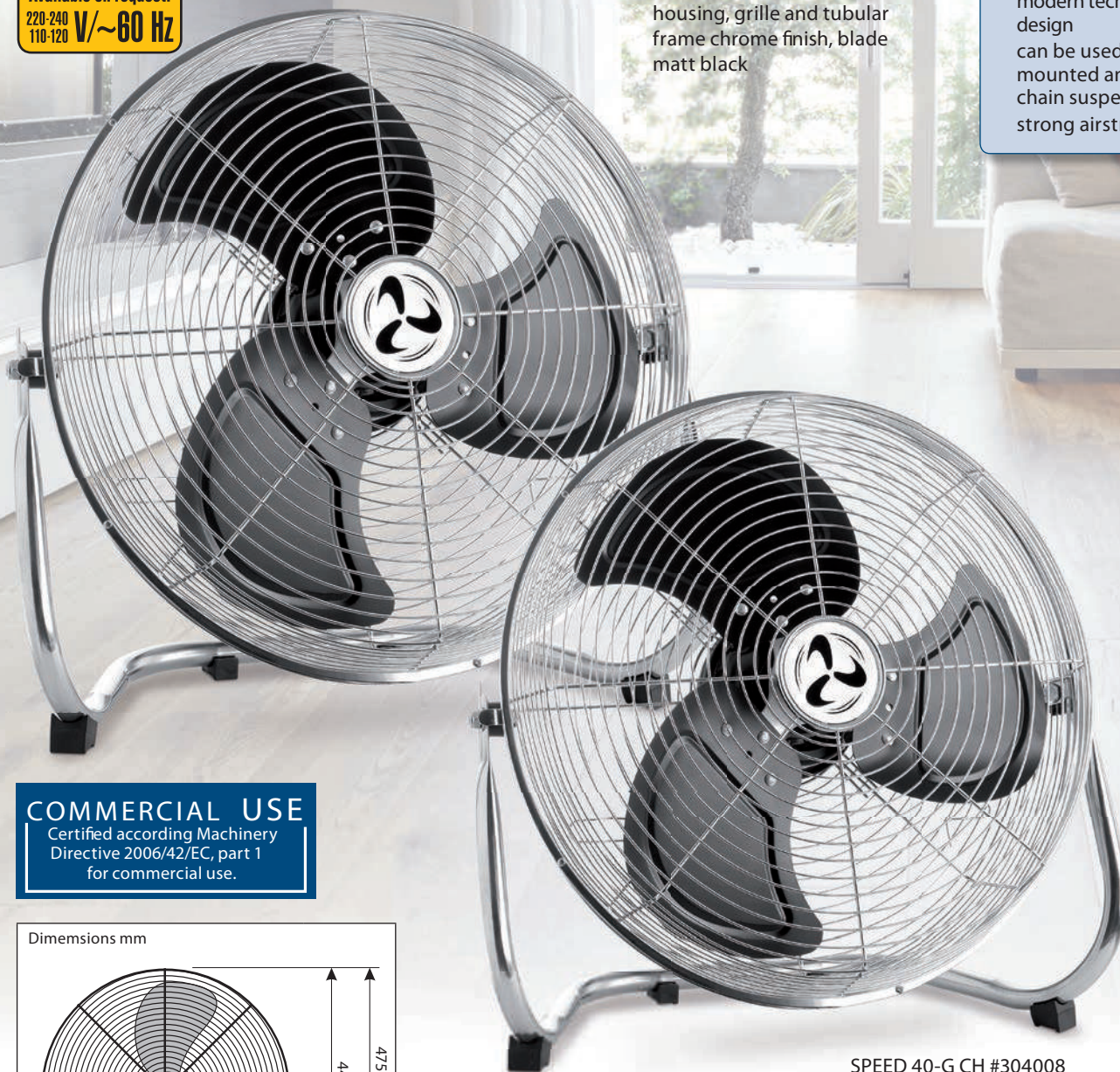

COMMERCIAL USE
Certified according Machinery
Directive 2006/42/EC, part 1
for commercial use.

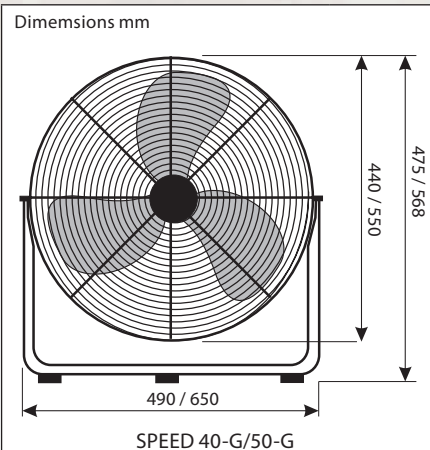

Model SPEED G	40	50
Blade Ø (mm)	400	500
Power motor (W)	110	120
Voltage (V/Hz)	220-240/~50	
No. of speeds	3	
Rev. max. (RPM)	1,305	1,310
Air delivery (m ³ /h)	5,685	7,860
Weight (kg)	4.6	5.5

SPEED 40-G CH #304008
housing, grille and tubular frame
chrome finish, blade matt black

The Fast and the Furious - wind, wherever you need it

Protective grille with chrome finish.
3-speed rotary switch at the back of the grille.
Vertical grade adjustable.
Product can be used wall mounted or with chain suspension (hooks included).
Stable, tilt-free, chromed tubular frame with rubber feet.

Useful transport handle and cable coil.
Powerful aluminium blade, matt black.
2.5 m supply cable, oil-resistant, rubber-insulated cable H05RN-F G 3 1.0 mm² with Schuko plug.
Optional 5 speed transformer ETWZ 1,0 #891020) for regulation between a whisper quiet breeze and high performance.

Product	Code No.	Grille Finish	Blade Finish	Grille Ø (mm)
SPEED 40-G CH	304008	Chrome	Matt black	440
SPEED 50-G CH	305008	Chrome	Matt black	550